

CAD FILE:

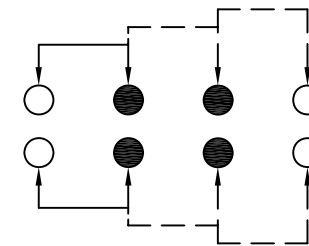

SCHEMATIC (NON-SHORTING)

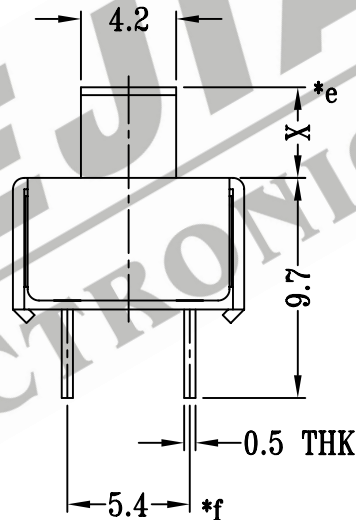
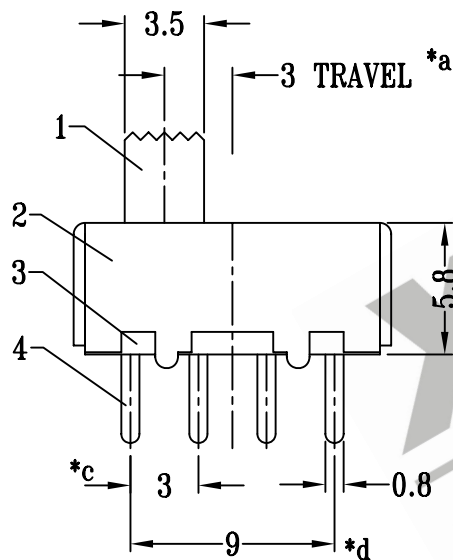
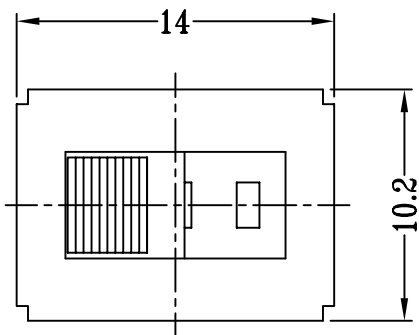
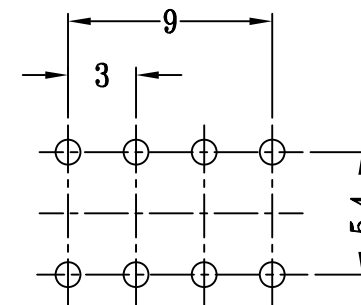

P.C.B LAYOUT

注:带**表示关键尺寸(6个)

| | | | | | | | | | | |
|-----|--------------|----------------|------|--------------------------|---|--------------------------------------|----------------------------|--------------------------|-----------|-------|
| 8 | | | | | TOLERANCE UNLESS SPECIFIED | SHENZHEN XIEJIA ELECTRONICS CO.,LTD. | | | | |
| 7 | STEEL BALL | STEEL | 1 | NATURAL | | | | | | |
| 6 | SPRING | STEEL WIRE | 1 | TEMPER | WITHIN: 1.5±0.1mm OVER: 1.5±0.2mm | ISSUE | DATE | DESCRIPTIONS OF REVISION | | APPD. |
| 5 | CONTACT CLIP | PBS STRIP | 2 | Ag PLATED | | | | | | |
| 4 | TERMINAL | BRASS STRIP | 8 | Ag PLATED OVER Ni PLATED | TITLE : VERTICAL SLIDE SWITCH | UNIT : mm | DRWG NO.: XJ-DR-SS23F15-00 | | | |
| 3 | BASE | PHENOLIC RESIN | 1 | NATURAL | | | | | | |
| 2 | FRAME | STEEL STRIP | 1 | Ni PLATED | MODEL: SS-23F15 | SCALE: 3:1 | DWN. | ZHOUYU | 2004-5-19 | |
| 1 | KNOB | POM | 1 | BLACK | | | CHK'D | FANGYING | 2004-5-19 | |
| NO. | PARTS | MATERIALS | Q'TY | FINISH | ALL MATERIALS MUST BE COMPLIANT TO ROHS | | APPD. | KANGXINAN | 2004-5-19 | |